

LZ2–B855E · B856E

**Electronic Single Needle Zigzag
Lock Stitcher**
**Electronic Single Needle Zigzag
Lock Stitcher with Thread Trimmer**



Specifications

	B855E - 1, B855E - 1/BT, B856E - □01 (Foundation)	B855E - 3, B856E - □03 (Long stitch)
Sewing speed	5,000rpm (*1)	
Zigzag stitch	Zigzag width : 8 mm	
Feed mechanism	Bottom feed	
Max. feed amount	2.5 mm	5 mm
Height of presser foot	Manual 6 mm Knee 10 mm	
Needle	Schmetz SY1965 Nm10	
Needle stroke	33.3 mm	
Thread trimmer	B856E : Included	
Automatic presser foot lifter	B856E - 901, 903 : 7 mm	
Thread take up	Rotary	
Presser pressure	19.6 – 58.8 N (2 - 6 kgf) (*2)	19.6 – 58.8 N (2 - 6 kgf)
Height of feed dog	1.0mm	
Arm pocket area	W 269 × D178 mm	
Motor	400 W induction motor (Single / Three-phase) Three-phase 200V, 220V, 380V, 400V, 415V, Single-phase 100V, 110V, 220V, 230V, 240V 50, 60 Hz W332 × D253 × H285 mm	
Control box		

*1. At the time of shipment from the factory, the maximum sewing speed is set to 4,500 rpm.

For some patterns, the maximum sewing speed may be limited by the zigzag width that has been set.

*2. For –1 specifications, a 9.8 – 29.4 N (1 - 3 kgf) presser spring is provided as an accessory.

LZ2-B855E-

Use	
1	General (foundation)
3	General (long stitch) *2

LZ2-B855E- **BT**

Use	
1	General (foundation)

With back tack / condense device

LZ2-B856E- **0**

	Thread trimmer	Upper thread feeding device	Back tack / Condense device *1	Thread wiper	Solenoid type presser foot lifter	Use	
3	○	○	○	—	—	1	General (foundation)
4	○	○	○	○	—	3	General (long stitch) *2
9	○	○	○	○	○		

*1. Condensed stitches and back tack stitches can be sewn.

*2. If fine adjustments to the stitch length are needed, use "General (foundation)".

Gauge parts list

[Models LZ2-B855E, B856E]

Zigzag width	Needle plate	Presser foot assy	Feed dog	Stopper
8 mm	S48064-001 	S48293-001 	S48143-101 	S48073-000 Snow-white color
	S48065-001 	S48299-001 	S48145-101 	
		S48305-001 		
5 mm	S48066-001 	S48308-001 	S06171-101 	S48074-000 Black color
	S48067-001 			
	S06166-001 			
3 mm	-	-	-	S48075-000 Blue color

Gauge parts list

[Models LZ2-B855E, B856E]

Zigzag width	Needle plate	Presser foot assy	Feed dog	Stopper
10 mm	S50684-001 	S51227-001 	S50686-001 	S52046-000 Snow-white color
	S50685-001 	S51231-001 		

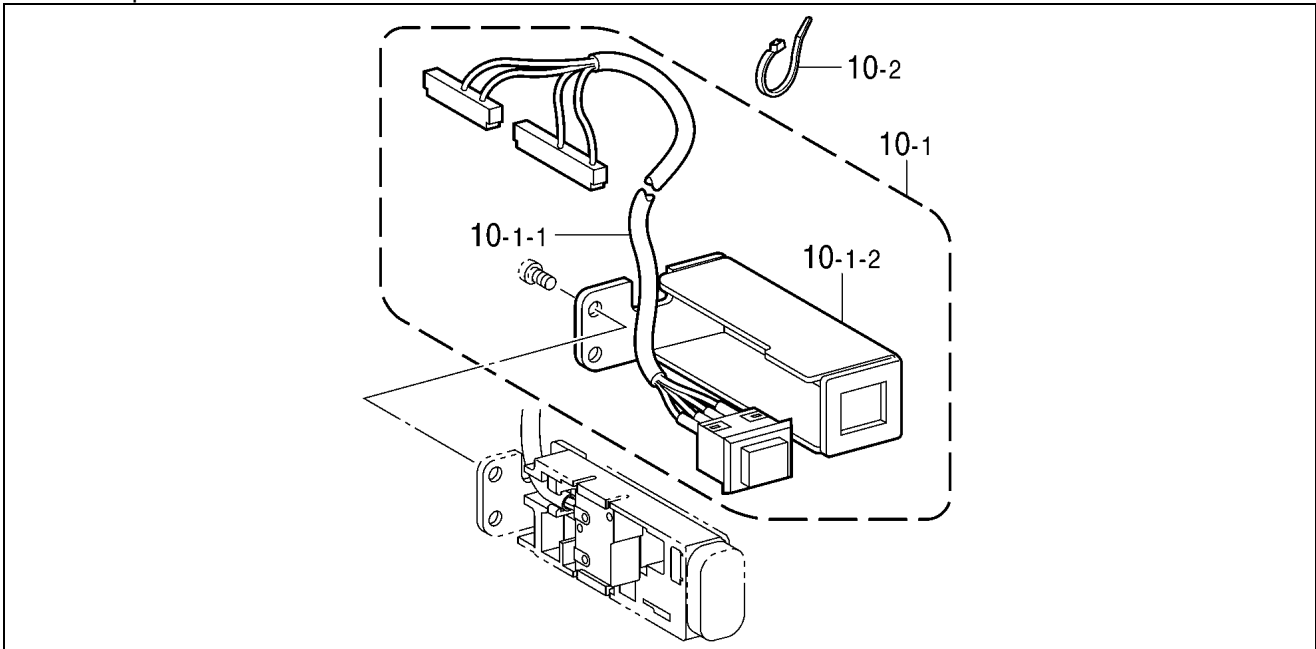

Ref. No.	Part name	Part code	Q'ty
10	Reflection pattern switch set	S80013-001	1
10-1	Reflection pattern switch assy	S50678-001	1
10-1-1	Harness assy, R-pattern switch	S49937-000	1
10-1-2	Switch holder	S48380-001	1
10-2	Band, PLTIM	S04557-000	3

The following parts are use carbide for their tips.

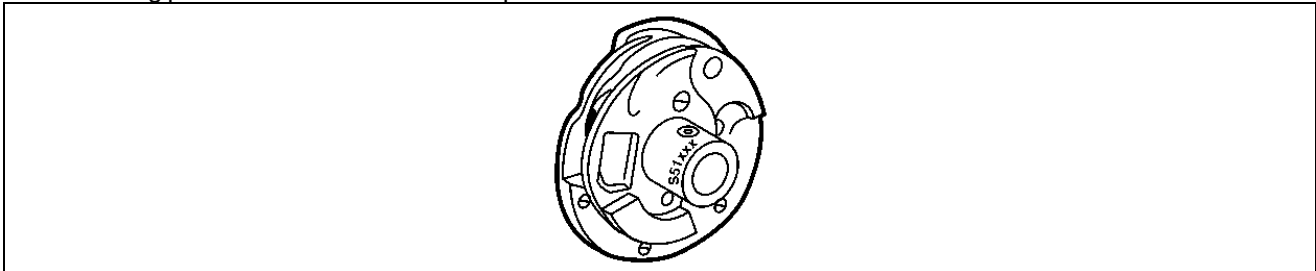

Part name	Part code	Q'ty
< For "B855E & B855E/BT" > Rotary hook assy, HP w/box	S51821-901	1
< For "B856E" > Rotary hook assy, HP w/box	S51822-901	1

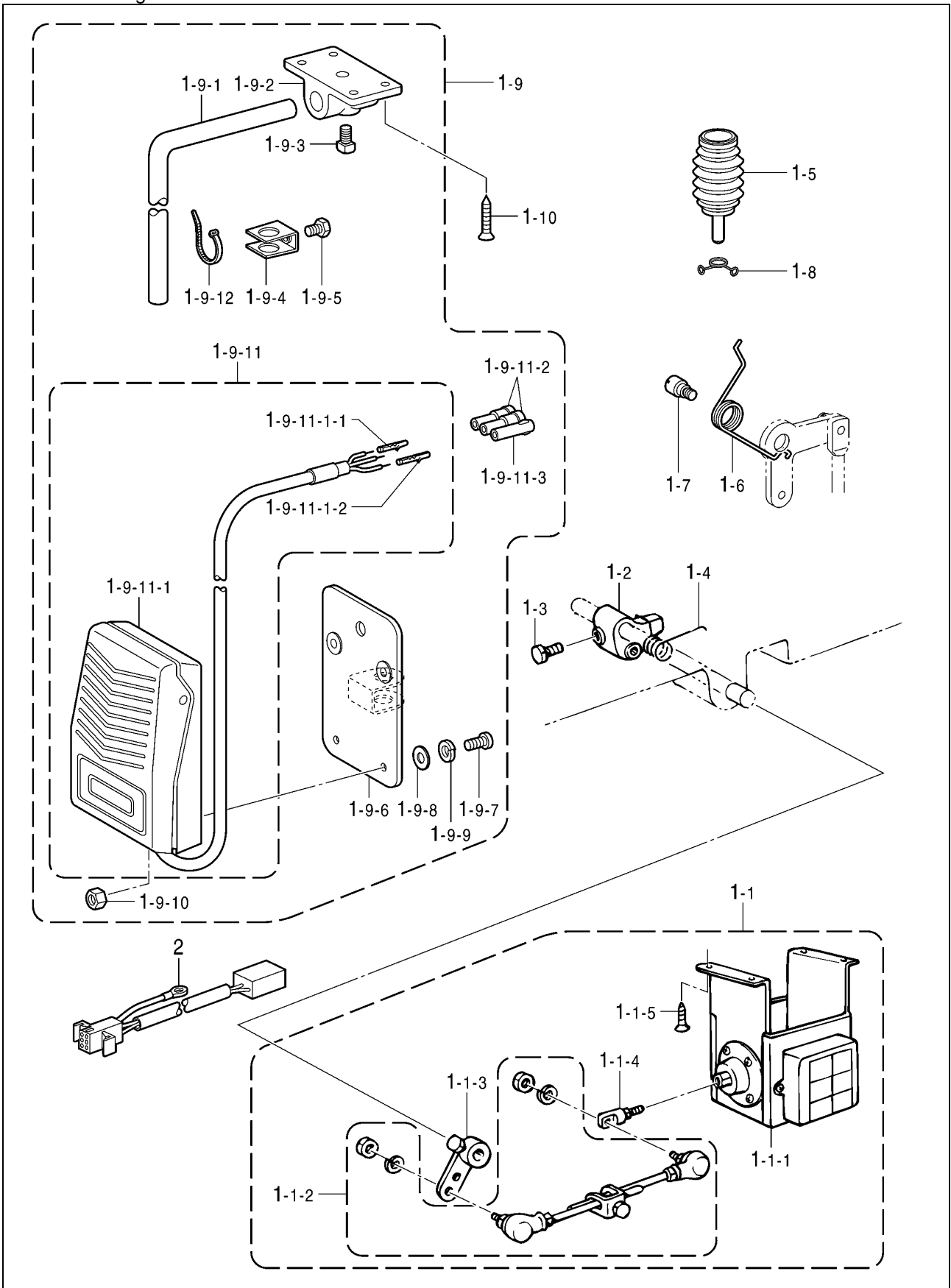

Presser foot lifting solenoid set

Ref. No.	Part name	Part code	Q'ty
1	P-foot lifter solenoid set, 1D	183967-001	1
1-1	P-foot lifter solenoid set, 4	183962-151	1
1-1-1	P-foot lifter solenoid assy	S42963-051	1
1-1-2	Presser foot lifter rod assy	S42198-051	1
1-1-3	P-foot lifter lever assy	S42199-051	1
1-1-4	Rod joint assy	S41955-051	1
1-1-5	Wood screw	S42200-051	4
1-2	Presser foot lifter link	S02595-101	1
1-3	Bolt, SM5.95	146367-001	1
1-4	Spring, twist	S02596-001	1
1-5	Knee lifter complying bar assy	S16250-001	1
1-6	Spring	154347-001	1
1-7	Shoulder screw, SM6.35	S31010-001	1
1-8	Clip	S07015-001	1
2	Relay harness	S47686-000	1

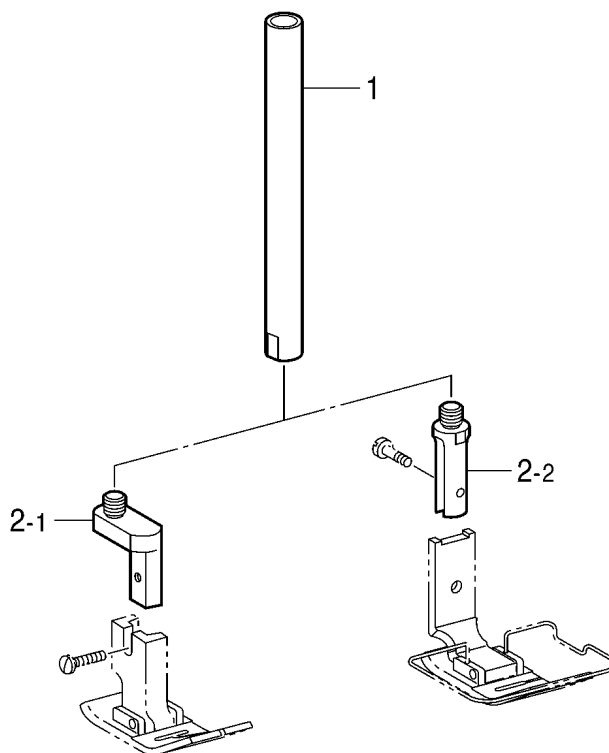

Ref. No.	Part name	Part code	Q'ty
1	Presser bar, U < For presser foots for lock stitch >	S50114-001	1
2-1	Presser bar tip, A < For standard presser foots >	S50115-001	1
2-2	Presser bar tip, B	S50116-001	1